

- △ HOUSING MATERIAL: LIQUID CRYSTAL POLYMER  
COLOR: NATURAL.
- △ CONTACT MATERIAL: PHOSPHOR BRONZE PER UNS  
ALLOY NO. C51100, TEMPER: H04.
- △ CONTACT FINISH:  
UNDERPLATE (ENTIRE CONTACT):  
0.00127 MIN NICKEL.  
ON MATING SURFACES:  
CONFORMS TO ALL TESTING SPECIFIED FOR TELCORDIA  
UNCONTROLLED ENVIRONMENT.  
ON LEADS  
0.00381 MIN TIN-LEAD OVER UNDERPLATE.  
LUBRICATION (ENTIRE CONTACT):  
SURFACE CONDITIONER PER AMP SPEC 112-1002 AFTER PLATING.
- △ PART MARKINGS LOCATED APPROXIMATELY AS SHOWN.
- △ PART TO BE MARKED WITH DATE CODE ONLY.

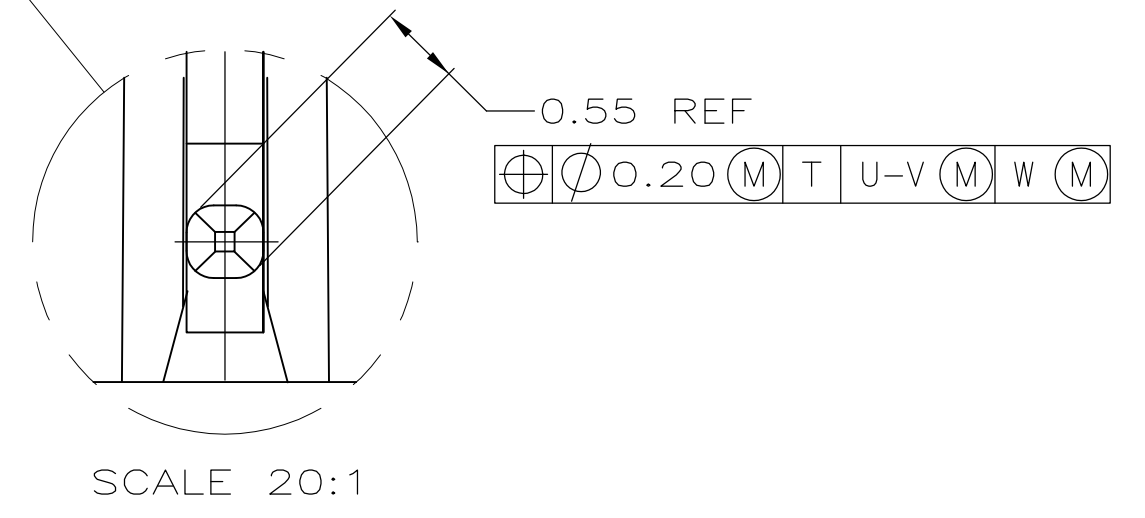
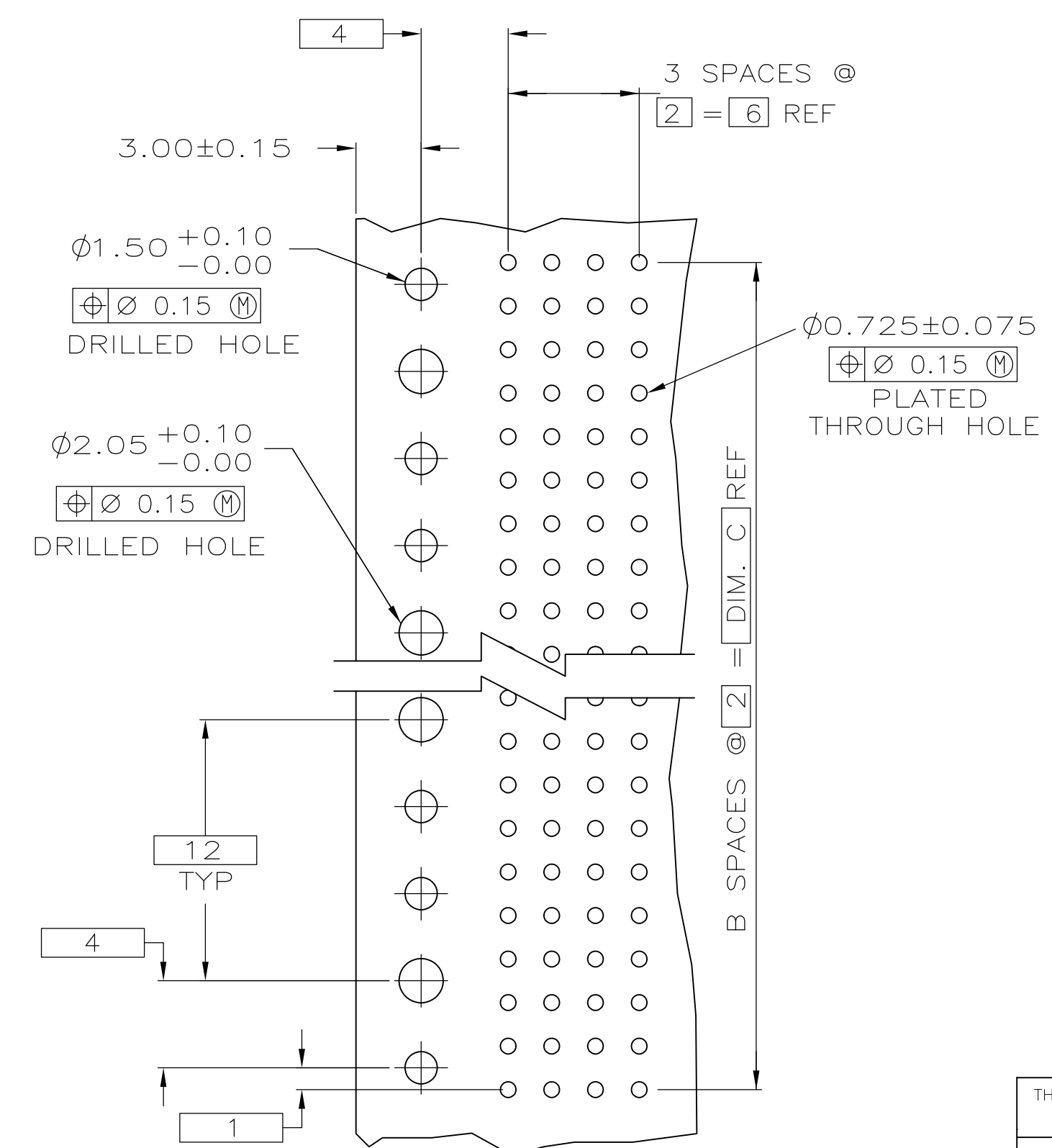
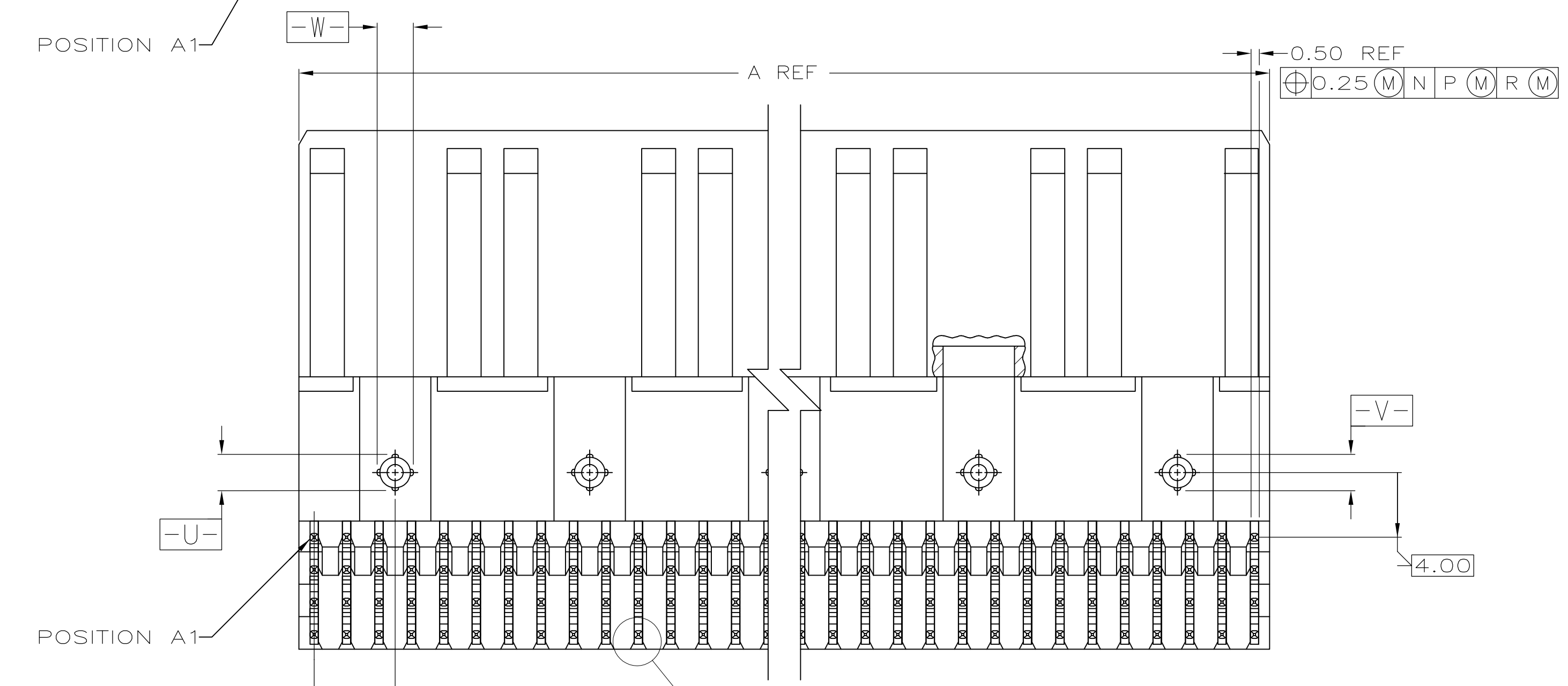
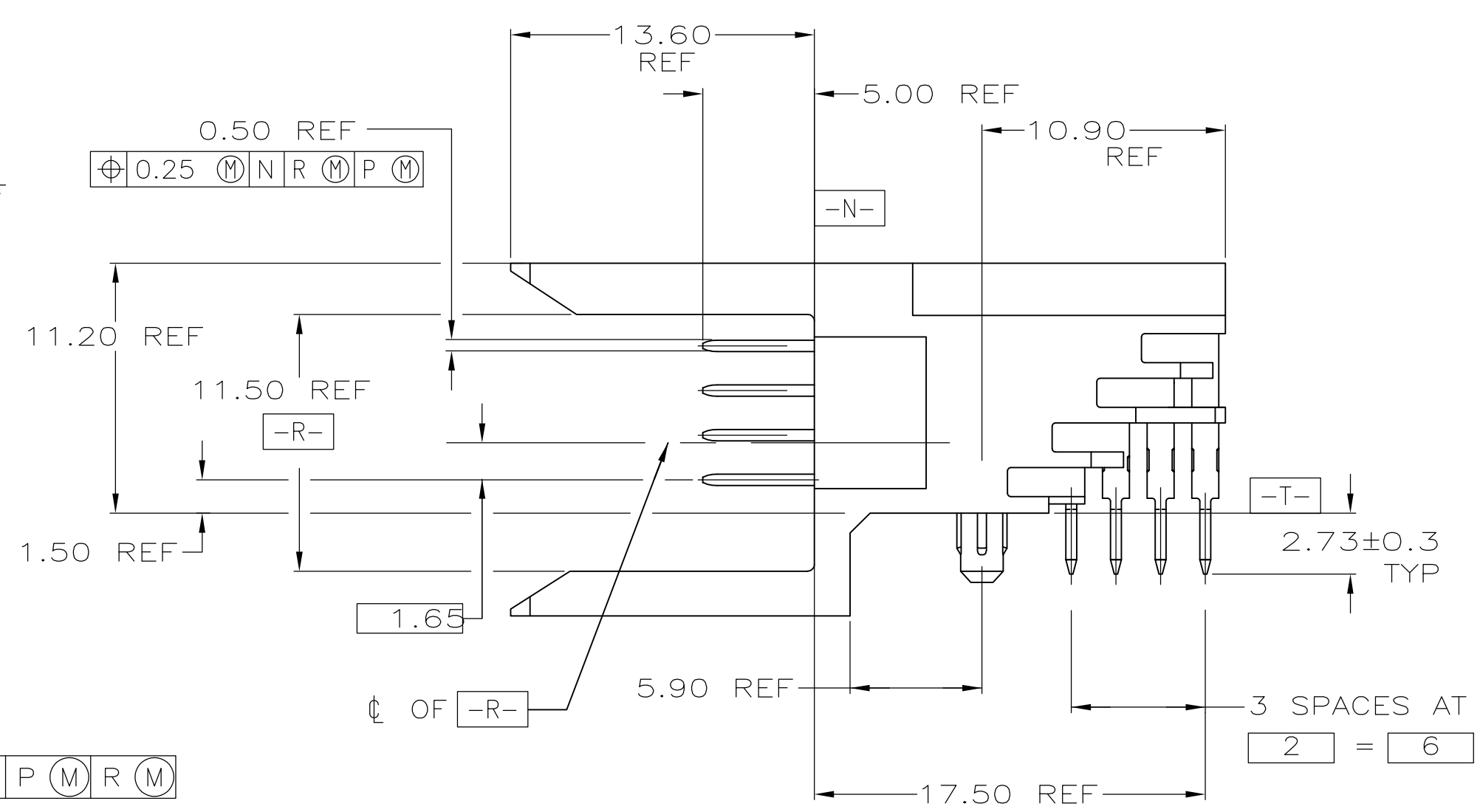
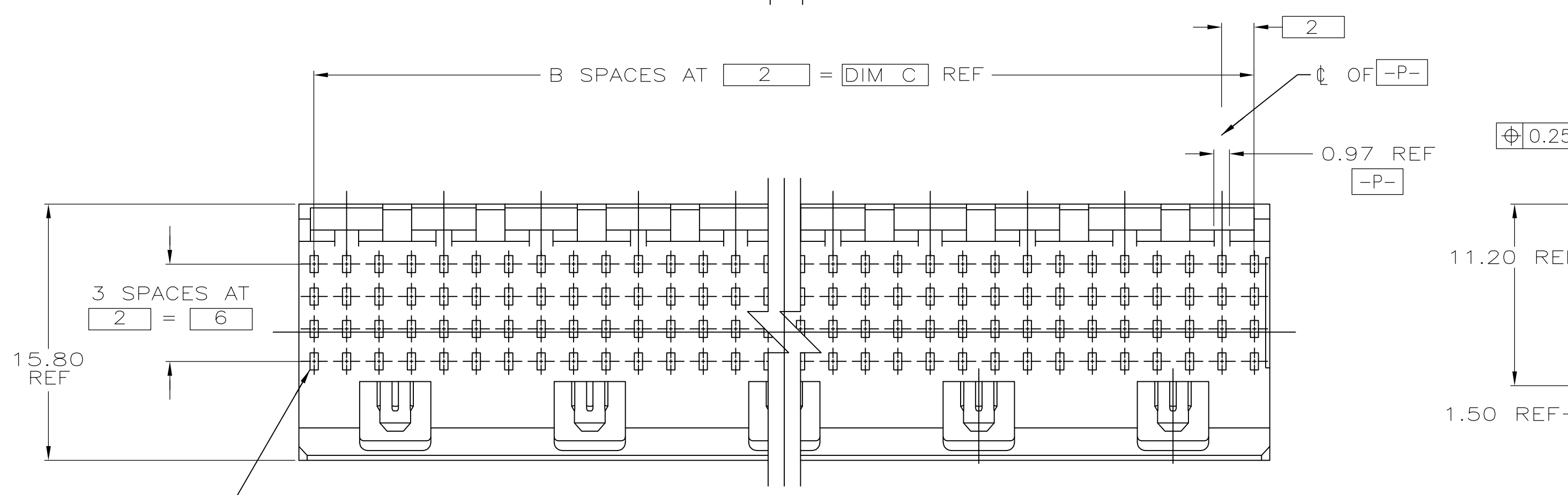

SCALE 20:1

RECOMMENDED CIRCUIT PATTERN  
PER IPC-D300 TYPE II, CLASS C  
(COMPONENT SIDE)

82	41	83.88	△ 3	168	223513-8
34	17	35.88	△ 3	72	223513-7
58	29	59.88	△ 3	120	223513-6
70	35	71.88	△ 3	144	223513-5
94	47	95.88	△ 3	192	223513-4
46	23	47.88	△ 3	96	223513-3
22	11	23.88	△ 3	48	223513-2
10	5	11.88	△ 3	24	223513-1
C	B	A	FINISH	NO OF POSN	PART NUMBER

THIS DRAWING IS A CONTROLLED DOCUMENT.

DIMENSIONS:	TOLERANCES UNLESS OTHERWISE SPECIFIED:	DATE	06/JUL/95
mm	0 PLC ± -	CHK	R. BUCHHEISTER
	1 PLC ± -	DATE	04/AUG/95
	2 PLC ± 0.13	APVD	D. BAECHTLE
	3 PLC ± -	PRODUCT SPEC	
	4 PLC ± -	APPLICATION SPEC	
	ANGLES ± -	NAME	ASSEMBLY, PIN, SIGNAL, RIGHT ANGLE, 4 ROW, Z-PACK 2mm FB
MATERIAL	FINISH	SIZE	A1
△ 1 △ 2	△ 3	WEIGHT	00779
CUSTOMER DRAWING		SCALE	4:1
		SHEET	1 OF 1
		REV	P2

Tyco Electronics Corporation  
Harrisburg, PA 17105-3608